

# 285B-6-AP Air Impact Wrench Exploded Diagram

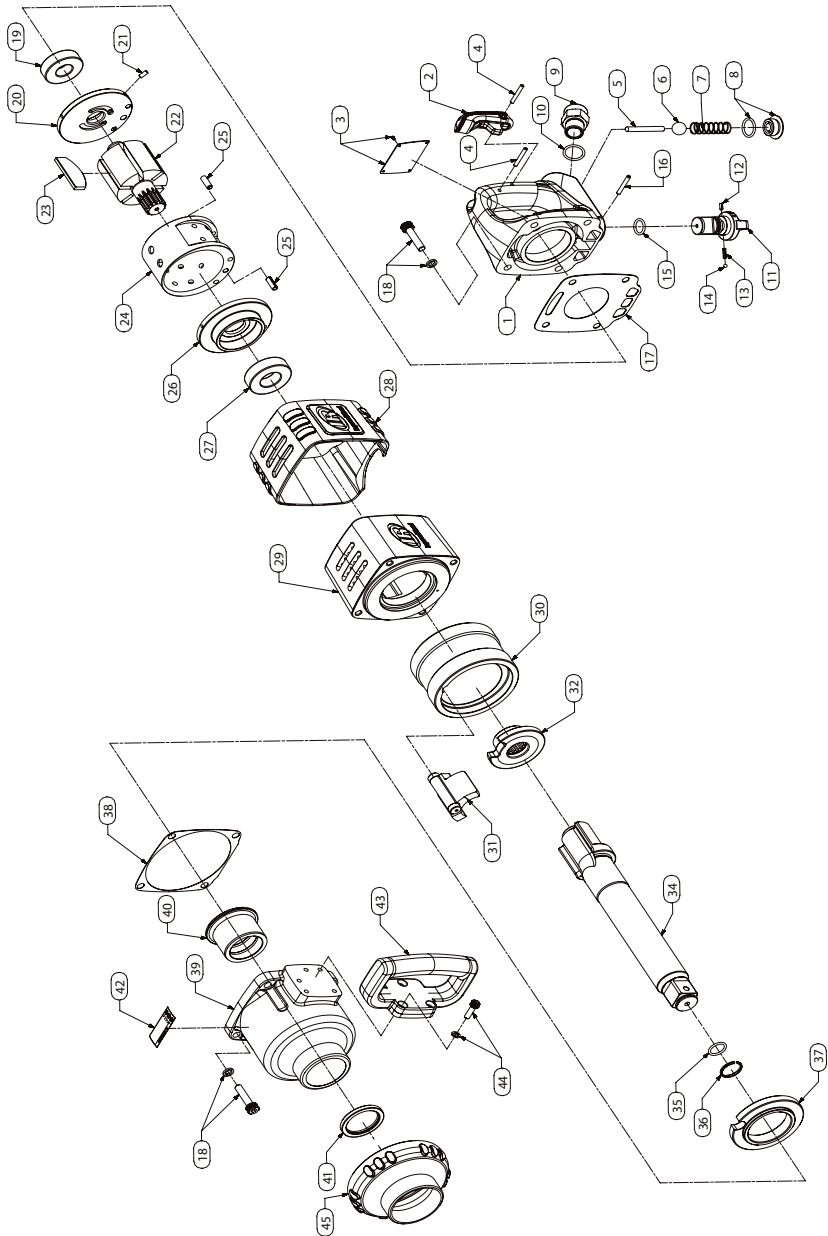

(Dwg. 16586711)



## 285B-6-AP Air Impact Wrench Parts List

Item	Part Description	Part Number	Item	Part Description	Part Number
1	Trigger Handle Assembly	431L-A92A	24	Cylinder and Alignment Pins	285B-A3
2	Trigger	431L-93	25	Pin, Spring (2)	--
3	Nameplate and 4 rivets	285B-AP-A301	26	Front End Plate	285B-11
4	Pin (2)	431L-437	27	Front Rotor Bearing	285B-96
5	Plunger, Throttle Valve	285B-302	28	Tool Guard	431L-32
6	Throttle Valve	285B-50	29	Motor Housing, top exhaust	431L-40
7	Spring, Throttle Valve	285B-51	30	Hammer Frame	285B-703
8	Plug and Seal	431L-A202	31	Hammer	285B-724
9	Inlet Bushing Assembly	285B-A565	32	Hammer Cam	285B-721
10	O-Ring	285B-566	34	Anvil Assembly, 6" extended Length	285B-A726-6
11	Reverse Valve Assembly	285B-A329	35	O-Ring	BBFM-557
12	Stop Pin	285B-332	36	Retainer Ring	910E5-918
13	Spring	285B-334	37	Side Plate	285B-706
14	Ball	285B-333	38	Hammer Case Gasket	285B-36
15	Reverse Valve Seal	285B-338	39	Hammer Case Assembly	285B-A727
16	Pin, Spring	285B-120	40	Hammer Case Bushing	285B-641
17	Gasket, Handle	285B-283	41	Oil Seal	285B-642
18	Handle Cap Screw and washer (Set of 8)	285B-A638	42	Warning Label	WARNING-2-99
19	Rear Rotor Bearing	285B-24	43	Dead Handle (Straight) with screws	285B-A48
20	End Plate with alignment pin	285B-A12	44	Screw and Washer (3)	--
21	Pin, Spring	--	45	Hammer Case Guard	431L-62
22	Rotor	285B-53			
23	Vane Pack (Set of 6)	285B-42-6		Tune up kit (includes items 5, 6, 7, 10, 12, 13, 14, 15, 16, 17, 19, 23, 27, 35, 36, 38 & 41)	285B-TK1

### Parts and Maintenance

When the life of the tool has expired, it is recommended that the tool be disassembled, degreased and parts be separated by material so that they can be recycled.

Tool repair and maintenance should only be carried out by an authorized Service Center.

Refer all communications to the nearest **Ingersoll Rand** Office or Distributor.

### Related Documentation

For additional information refer to:

Air Impact Wrench Safety Information Manual Form 04580916.

Air Impact Wrench Product Information Manual Form 45573011.

Manuals can be downloaded from [www.irtools.com](http://www.irtools.com).